

Instructions

Mains Operated Alarm

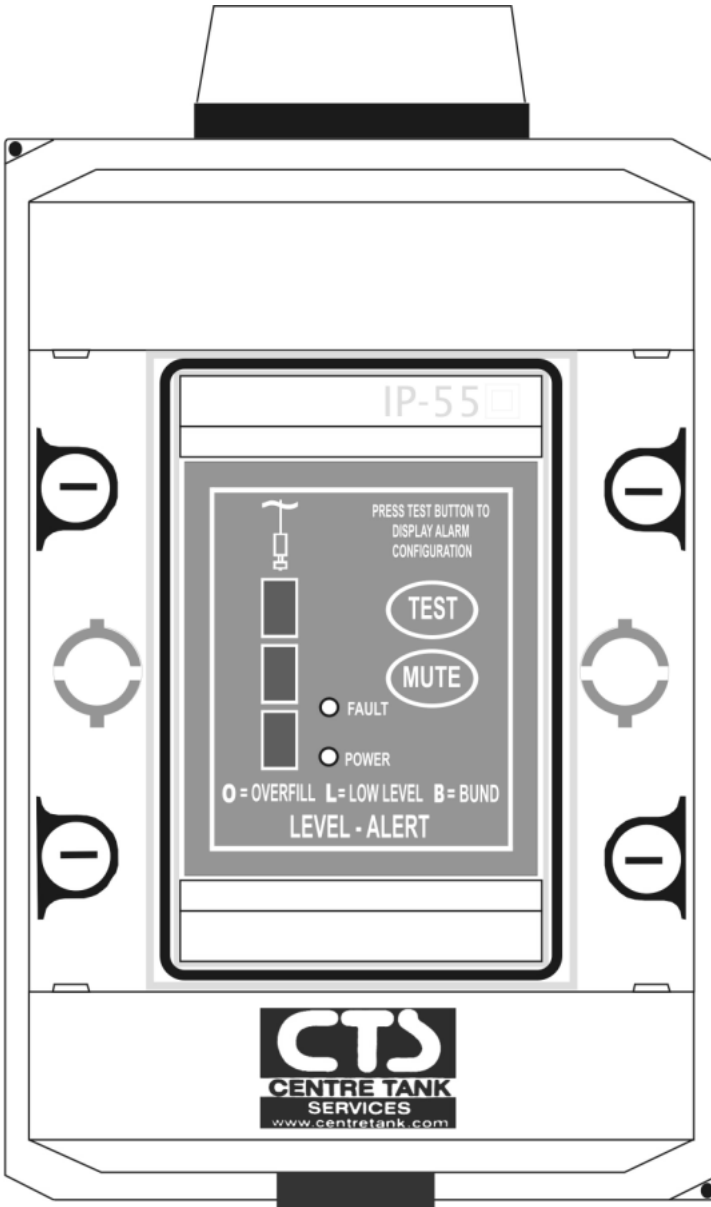

Index

Page	Section
2	Index
	Warning
3	Mounting and basic installation
4	Setting up the alarm
	Preliminary checks
5	Probe positioning
6—7	Internal Layout diagrams
8	Installation diagrams
	Power input
9	Probe connections
	Common probe connection
10	Zone & Option Switches
	Optional extras
	Relay outputs
11	Troubleshooting
	Alarm conditions
12	Technical specifications
	CTS contact details

WARNING: Electricity Can Kill

Before connecting the alarm
always disconnect the supply at the consumer unit.

If in **any** doubt consult a qualified electrician.

Mounting and Basic Installation

This alarm is designed to be installed in exposed locations. Care must be taken at all times to ensure that the front panel integral seal is not damaged resulting in water ingress.

1. Remove the Perspex door. Open the door by turning the white tab 90° anticlockwise.
2. Remove the front panel by turning the four plastic screws anticlockwise half a turn.
3. When all four screw slots are vertical the front panel can be lifted free from its base. **(N.B. Do not allow the front panel to hang unsupported on its cables.)**
4. Carefully drill out the four mounting holes in the base.
5. Use the holes as a template to mark the mounting surface.
6. Cable entry grommets must be positioned at the bottom.
7. Screw the base to the mounting surface and insert the four sealing caps into the screw recesses to prevent water ingress. **(N.B. When mounting ensure the base is flat and not distorted as this may result in water ingress.)**
8. Pass the sensor probe cable through the grommet and connect to the probe screw terminal. Repeat the procedure for the second probe. (See page 9 for more detail.)
9. Ensure the power supply is not live then connect the power cable. (See page 8 for more detail.)
10. Refit the front panel and door, ensuring that all integral seals are undamaged.

Setting Up The Alarm

Preliminary Checks

Now the alarm has been successfully mounted it is worth doing a few preliminary checks to ensure that the installation will run smoothly. It is particularly important to check the probe as an error found after installation is much more time-consuming.

1. Checking the Power

Power LED should be illuminated. Press the 'test' button for 2 seconds to ensure the alarm is operational. If no zones are active all lights and the sounder will stop when the button is released.

2. Checking the probe

Before installing the probe sensors in the tank, manually move the float.

On the Overfill and Bund probes the alarm should sound and the correct lamp illuminate when the float is moved to the top of its shaft.

The Low level probe should sound

when the float is positioned at the bottom of the shaft.

If on the Overfill or Bund the alarm sounds when the float moves to the bottom of the shaft or if the Low Level float sounds at the top of the shaft then remove the float by taking off the cir-clip (see diagram). Next rotate the float through 180°, push it back onto the shaft and reinstate the cir-clip.

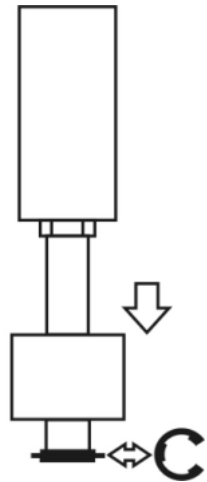

Setting Up The Alarm

Probe Positioning

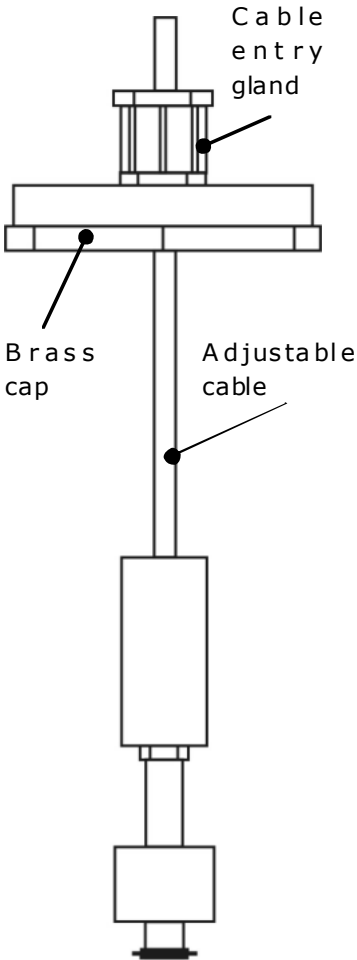

The position of the float can be adjusted to the required height by loosening the cable entry gland on the brass cap.

The cap can then be moved up or down the cable until the required height is achieved (see page 9: 'Probe connections' for more detail on positioning the probes in the tanks).

Retighten the cable entry gland and secure the cap to the tank.

To test the alarm press and hold the 'test' button, whilst the button is pressed all the configured zones, fault, strobe and sounder will activate. If no zones are active all lights and the sounder will stop when the button is released.

Periodically, and specifically before each filling to ensure unit has power and is operating correctly press and hold the 'test' button, all zones and large LED should illuminate and the sounder should activate.

Internal Layout Diagram

Power Supply Board

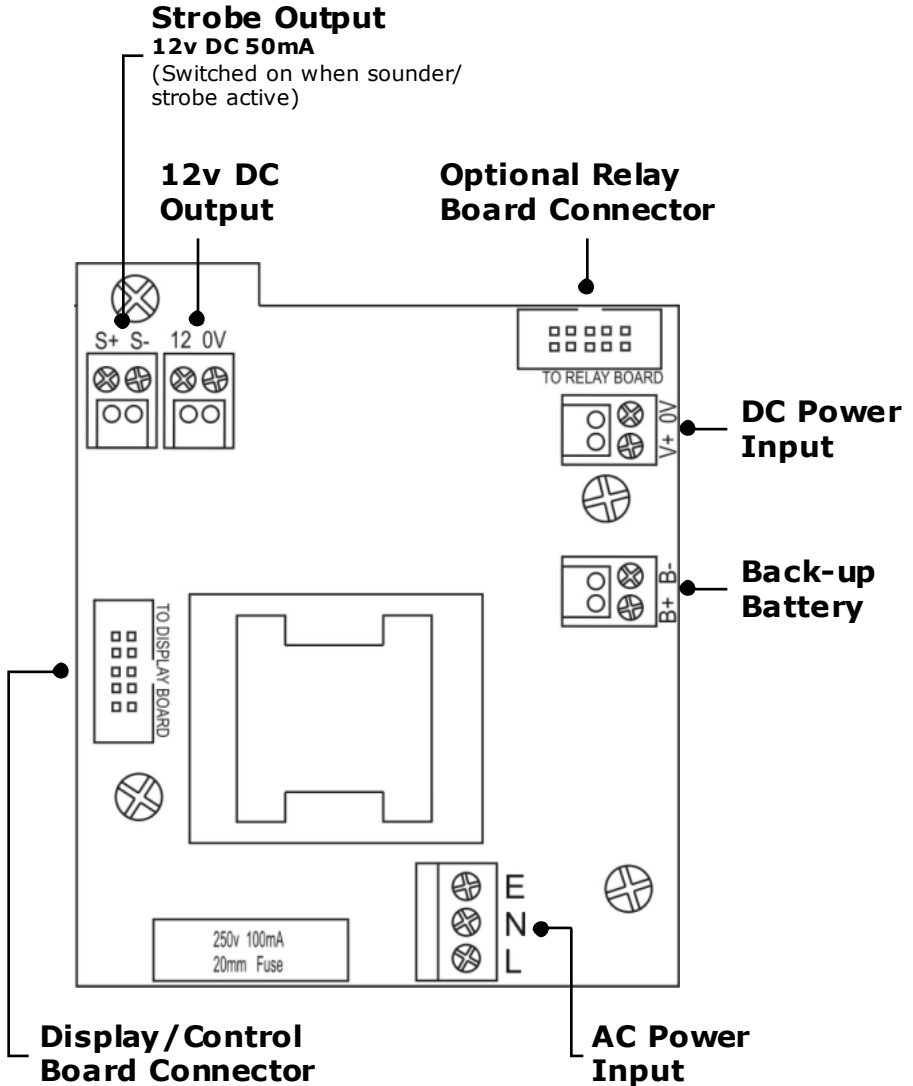

For more detail please see the following pages:

Power Input: page 8, **Optional Relays:** page 10

Internal Layout Diagram

Display / Control Board

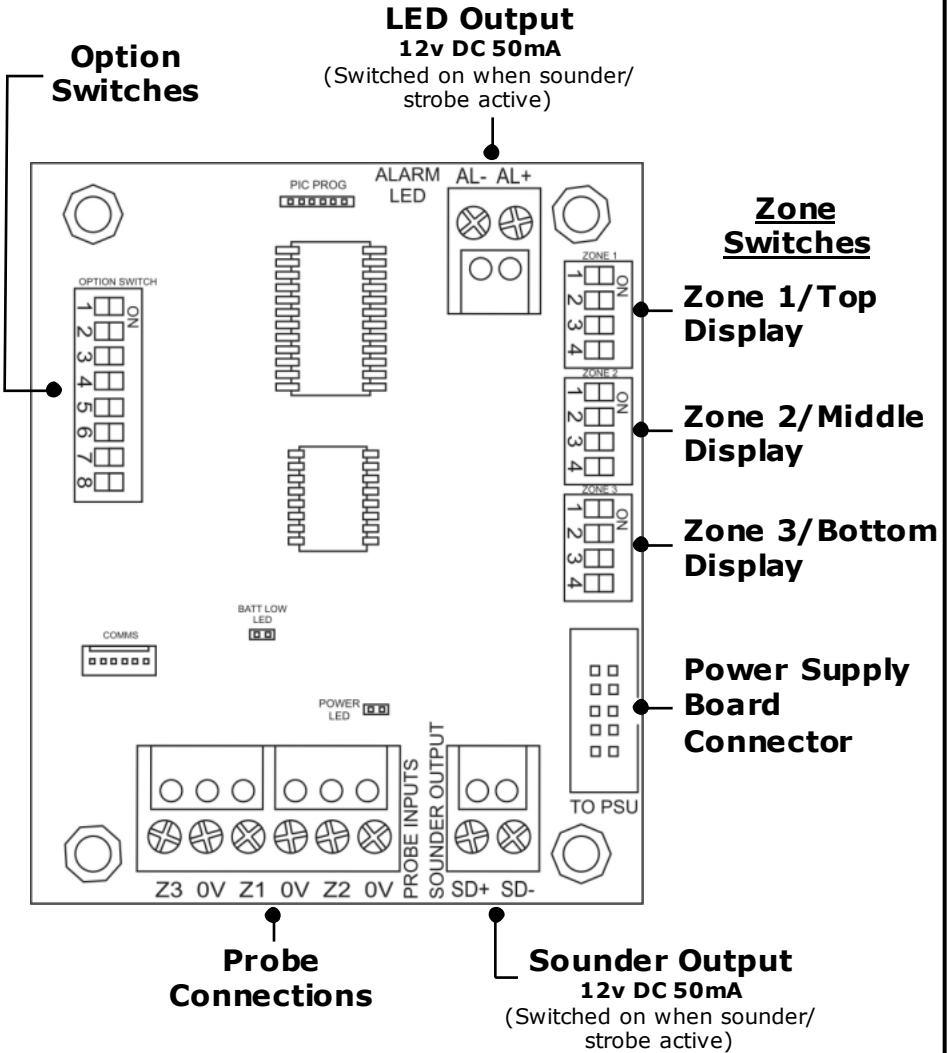

For more detail please see the following pages:

Probe Connections: page 9,

Option & Zone Switches: page 10

Installation Diagrams

Power Input

The unit is manufactured with a supply voltage of either 240v AC, 110v AC, 24v DC or 12v DC.

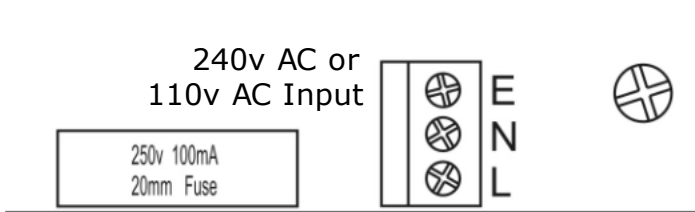

The bottom right of the board is marked with L, N and E, which stands for Live, Neutral and Earth, the brown wire goes to the bottom terminal (live), blue (neutral) goes to the middle and the yellow/green or bare wire (earth) goes to the top.

The DC supply, red wire should go to positive (V+) and black to negative (0V). It is important to take basic safety precautions and ensure the power is off during wiring.

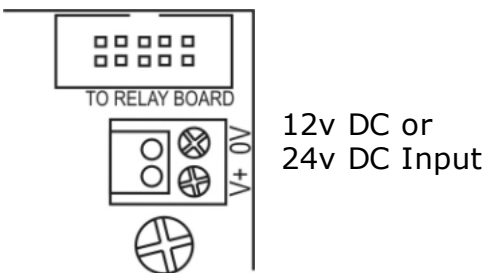

Note:

**Never connect both
AC and DC power
simultaneously to the
power supply as this
will damage the unit.**

If in **any** doubt consult a qualified electrician.

Installation Diagrams

Probe Connections

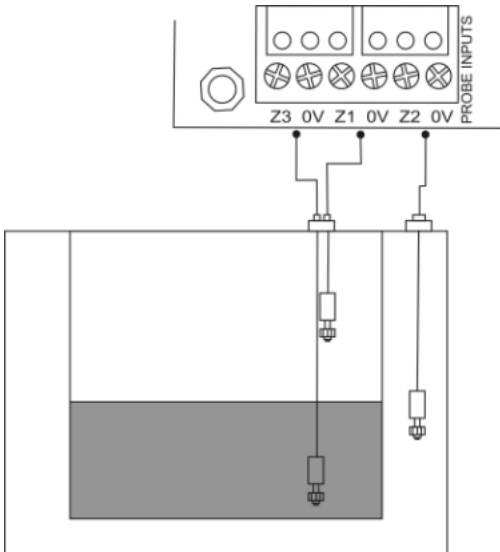

There are six probe connections, which are located as shown here. The probe wired to the 'High' connection is positioned topmost in the tank, and is used to alert that an overflow has occurred. Whereas the probe in the 'Low' connection should be placed near the bottom of the tank, to indicate a low level. The 'Bund' probe is between the two tank 'skins' and is a precaution so situations such as leakage and overflow can quickly be identified.

The 'Bund' probe is between the two tank 'skins' and is a precaution so situations such as leakage and overflow can quickly be identified.

Common Probe Connection

Typical system setting:

Zone 1 - Overfill Probe

Zone 2 - Bund Probe

Zone 3 - Low-level Probe

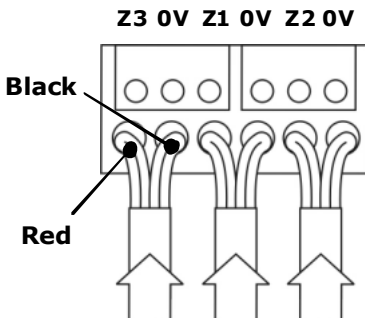

You will notice that in the probe cable there are two wires, one red and one black. The red wire should be connected to the Z(x) terminal and the black wire to the corresponding 0V terminal. The colour is actually irrelevant but it is suggested for simplicity all wires to the '0V' connections are kept the same. For Zone set-up see page 10.

Zone & Option Switches



To change the display adjust the Zone switches:

'O' - Switches 1, 2 & 3 ON

'L' - All switches OFF

'B' - All switches ON

The following functions can be set via the option switches:

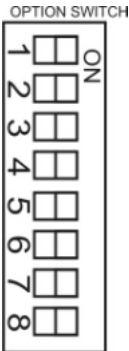

Switch 3 ON

Switch 3 OFF

1 & 2 OFF - Zone 1 only

1 OFF - Monitored Probes

1 ON, 2 OFF - Zones 1 & 2

1 ON - Standard Probes

1 OFF, 2 ON - Zones 1 & 3

2 OFF - Zone 3 N/O

1 & 2 ON - Zone 3 only

2 ON - Zone 3 N/C

4 ON - Battery Unit, LED off when mute pressed

5 ON - Relay ON Zone 3 activated, OFF Zone 1 activated

6 ON - No sounder on Zone 1 (muted)

7 ON - No sounder on Zone 1 or Zone 3 (muted)

8 ON - No sounder on Zone 3 (muted)

Relay Outputs (Optional)

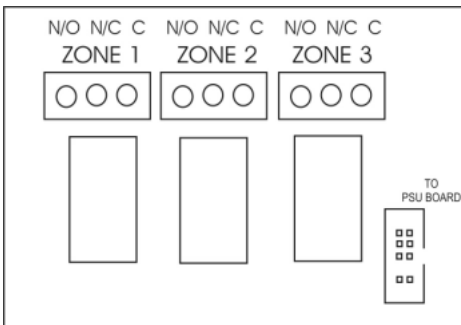

The relay outputs are optional and can be added to the unit at anytime. They allow switching to external equipment when either the High, Bund or Low alert is triggered. For example,

a pump is activated in the event of an overflow. 'C', 'N/O' and 'N/C' are printed on the boards for 'Common', 'Normally Open / Closed'.

It is important to note the **maximum switched voltage** is **250V AC** and the maximum switched current is **10 Amps**.

Troubleshooting

1. If the **power indicator** does not illuminate or sounder fails to react, check the power input to the unit (page 8).
2. If the **alarm activates signalling an overflow condition when the tank is not being filled**, this indicates a probe fault. Check cables and the probe assembly, make sure that the probe is in the correct position and not lying horizontally on the bottom of the tank.
3. If the **probe does not register as supplied**, then repeat sequence shown on page 4 (checking the probe).

Troubleshooting (Alarm Conditions)

1. The unit is designed so that all the zones emit a different sound, enabling you to distinguish the alarm zone without having to visualize it - the top zone is the most rapid (or urgent) on the sounder and the bottom is the least.
2. The Overflow Alarm will only activate when the tank has partially emptied and then been refilled.
3. The Bund Alarm indicates leakage from the tank. The outer cavity should be checked and drained if containing fluid.
4. The Low Level Alarm will only activate when the tank has partially filled and then the fuel drained below the low position.

Technical Specifications

Enclosure	
Dimensions (L x H x D)	145 x 242 x 110 (mm)
Colour	Light Grey RAL 7035
IP Rating	IP 55
Material	Polycarbonate
Float	
Material	Nylon
Specific Gravity	0.70
Operating Temperature	-30° C to +70° C
Cap Mounting Thread	1.5" BSP
Cable Length	5 metres
Sounder	
Frequency	2600 Hz
Sound Output @12V	90 dB
Supply Voltage (A.C.)	240v or 110v
Supply Voltage (D.C.)	24v or 12v



Centre Tank Services Ltd, Unit 41, Minworth Industrial Park,
Forge Lane, Minworth, Sutton Coldfield. B76 1AH

Website: www.centretank.com

Tel: **0121 351 4445** Fax: **0121 351 4442**

