

Technical Specifications

Enclosure	
Size (L x H x D)	105 x 170 x 98 mm
Rating	IP55
Colour	Light Grey RAL 7035
Material	GW Plastic
Power Requirements	110V AC (Mains)
Probe	
Cable Length	5 Metres
Material	Nylon
Contact Resistance	25mΩ
Max. Current	6mA @ 250V AC 15mA @ 100V DC
Life Expectancy	30E6 Operations
Float	
Material	Nylon
Specific Gravity	0.70
Sounder	
Volts	8-12V DC
Frequency	2600 Hz
Sound Output @ 12V	90 dB
Relay	
	10A (250V AC/30V DC)

CTS

Centre Tank Services Ltd, Unit 41, Minworth Industrial Park
Forge Lane Minworth, Sutton Coldfield B76 1AH



Tel: **0121 351 4445** Fax: **0121 351 4442**

Instructions

110v Mains Bund Alarm



Installation

⚠ **WARNING: Electricity Can Kill**

Before connecting the alarm

Always disconnect the supply at the consumer unit

If in **any** doubt consult a qualified electrician.

Location (Diagram)

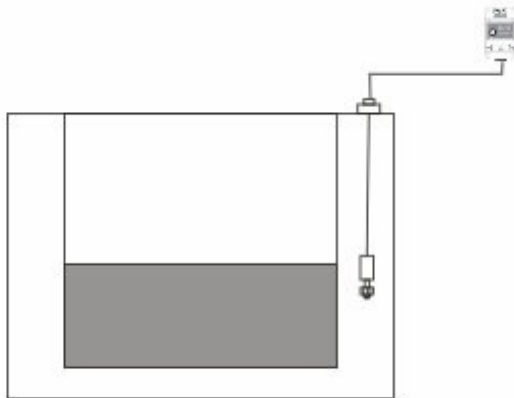

Layout (Diagram)

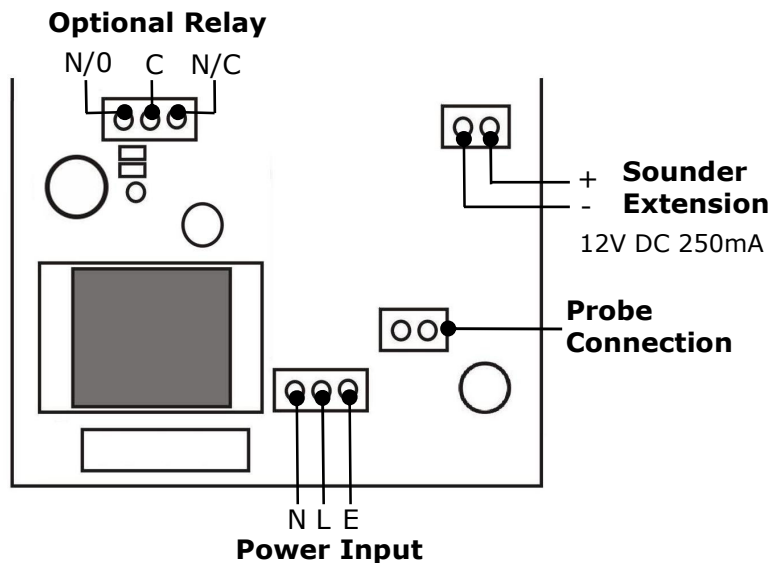

Installation

1. This device is designed to be installed in exposed locations; however, care must be taken when removing or fitting the front panel not to damage the integral seal allowing water ingress.
2. To remove the front panel, release the four metal screws located in the front panel recesses.
3. Remove the two knockout sections on the rear half of the enclosure and use the four holes created as a template to mark the mounting surface which should be flat in order that distortion of the enclosure resulting in water ingress does not occur.
4. Mount the rear half of the enclosure with the cable entry grommet at the bottom.
5. Having mounted the sensor probe in the storage tank to be monitored, pass the sensor cable through the cable entry gland. The two wires inside the sensor cable are then attached to the 'probe connection' (see layout diagram for location). Polarity is not important.
6. It is important to take basic safety precautions and ensure the **power supply is disconnected** during wiring. Next find the 'power input', the board is printed with N, L and E, which stands for Neutral, Live and Earth. Therefore, the blue wire goes to the far left (neutral), brown goes to the middle (live) and the yellow/green earth wire goes to the right (earth).
7. The front panel may now be refitted securely ensuring that no damage occurs to the integral seal.
8. Apply power. The sounder should operate upon pressing the test button, failure indicates that either there is a problem with the mains or the unit.
9. Test unit periodically by pressing test button.

On alarm the sounder is activated, the only way to then halt the sounder is by rectifying the problem (i.e. pumping the fuel from the bund.)